

Carrera[®]
DIGITAL 124

Carrera[®]
2.4 GHz WIRELESS+)))

20023621 RACE OF VICTORY

- D** Montage- und Betriebsanleitung
- GB USA** Assembly and operating instructions
- F** Instructions de montage et d'utilisation
- E** Instrucciones de uso y montaje
- P** Instruções de montagem e modo de utilização
- I** Istruzioni per il montaggio e l'uso
- NL** Montage- en gebruiksaanwijzing
- S** Monterings- och bruksanvisning
- FIN** Asennus- ja käyttöohjeet
- N** Montajse- og bruksanvisning
- H** Ósszeszerelési és használati útmutató
- PL** Instrukcja obsługi i montażu
- SK** Návod na montáž a pre prevádzku
- CZ** Návod na montáž a pro provoz
- BG** Ръководство за монтаж и експлоатация
- GR** Οδηγίες συναρμολόγησης και λειτουργίας
- RO** Instrucțiuni de montaj și de utilizare
- DK** Monterings- og driftsvejledning
- RC** 安装和使用说明
- J** 取扱説明書
- ROK** 조립과 작동 방법
- Arabic** إرشادات التركيب و الاستخدام
- TR** Montaj ve işletme kılavuzu
- RUS** Инструкция по монтажу и эксплуатации

Verpackungsinhalt · Contents of package · Contenu du carton · Contenido de la caja · Conteúdo da embalagem · Contenuto della confezione · Verpakkinginhoud · Innehållet i förpackningen · Pakkauksen sisältö · Innholdet i pakningen · A csomag tartalma · Zawartość opakowania · Obsah balenia · Obsah balení · Съдържание на опаковката · Περιεχόμενα συσκευασίας · Conținutul ambalajului · Emballageinhold · 包装内容 · 梱包内容 · 포장내용물 · محتويات الغلاف · Ambalaj içeriği · Содержимое картона

20023621 RACE OF VICTORY

1x [Image of car] 1x [Image of car] 1x [Image of manual] 4x [Image of screw] 1x [Image of battery] 1x [Image of receiver] 1x [Image of transmitter] 2x [Image of battery] 1x [Image of transmitter] 1x [Image of transmitter] 1x [Image of transmitter] 11x [Image of track piece A] 11x [Image of track piece C] 146x [Image of track piece D] 8x [Image of track piece D] 2x [Image of track piece E] 2x [Image of track piece F] 1x [Image of track piece E] 2x [Image of track piece F] 8x [Image of track piece G] 8x [Image of track piece H] 8x [Image of track piece I] 8x [Image of track piece K] 2x [Image of track piece L] 4x [Image of track piece M]

1x 44 cm/17.32 inch [Image of track piece D]
 1x 60°/74 cm/29.13 inch [Image of track piece O]
 1x 180°/178 cm/70.08 inch [Image of track piece P]
 1x 240°/232 cm/91.34 inch [Image of track piece O]

2x [Image of track piece L]
 3x [Image of track piece M]
 3x [Image of track piece M]
 31x [Image of track piece D]

Officially licensed by AUDI AG.
 „Mercedes-Benz”, [Image of Mercedes-Benz logo] and the design of the enclosed product are subject to intellectual property protection owned by Daimler AG. They are used by Stadlbauer Marketing + Vertrieb GmbH under license.

Ausbauvorschläge · Proposals for extension · Suggestions d'extension · Propuestas de ampliación · Propostas de expansão · Proposte di ampliamento · Uitbreidingsvoorstellen · Monteringsförslag · Rakennelmaehdotuksia · Streckningsförslag · Kiéripítési javaslatok · Propozycje rozbudowy · Návrhy výstavby · Návrhy výstavby · Предложения за демонтаж · Протάσεις επέκτασης · Propuneri de asamblare · Udvidelsesforslag · 多项扩充建议 · 拡張提案 · 기타 조립 예 · اقتراحات للتوسيع · Genişletme önerileri · Предложения по расширению

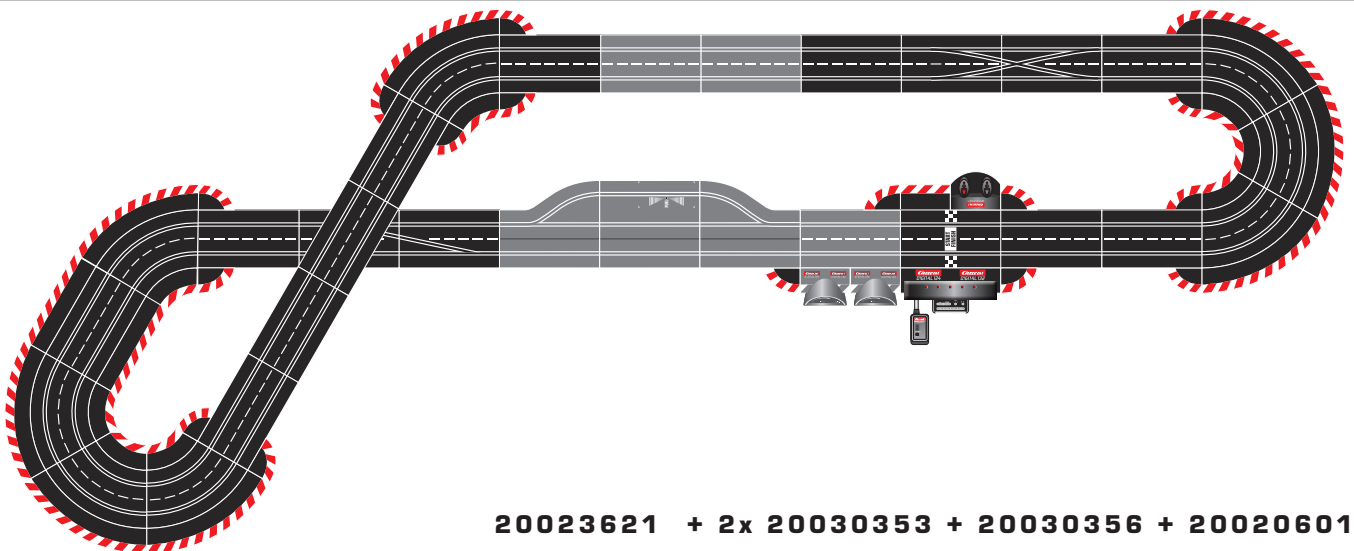

20023621 + 2x 20030353 + 20030356 + 20020601

Table of contents

Safety instructions	11
Declaration of Conformity	11
Contents of package	11
Technical advice for assembly	11
Important Information	12
Description	12
Before first use	12
Care of the battery	12
Assembly instructions	12
Guard Rails and Supports	12
Electrical connection	12
Car components	12
Connections Control Unit	13
Connecting the receiver	13
Connecting the charging unit	13
Charging the speed controllers	13
Binding process	13
Control elements Control Unit	13
Encoding/programming of cars to the according speed controllers	13
Preparation of start	14
Points function	14
Light function on/off	14
Encoding/programming of Autonomous Car	14
Encoding/programming Pace Car	14
Display of position Autonomous and Pace Car	14
Setting of the cars' basic speed	14
Setting of cars' braking performance	15
Setting fuel tank capacity	15
Deactivating Settings Keys	15
Extended Pit Lane function	15
Sound ON/OFF	15
Reset function	16
Energy-saving mode	16
Replacement of double sliding contact and guide keel	16
Height adjustment car chassis	16
Changing the light board	16
Maintenance and care	17
Troubleshooting/Driving tips	17
Technical specifications	17
Requirement for FCC Part 15	17
Warnings	17

Welcome

Welcome to the Team Carrera!
These operating instructions contain important information regarding the assembly and operation of your Carrera DIGITAL 124 race track. Please read them carefully and keep them in a safe place afterwards. If you have any queries, please do not hesitate to contact our distributor or visit our website: carrera-toys.com

Please check the contents for completeness and possible transport

damage. The packaging contains important information and should also be retained. We hope you will derive a lot of pleasure from your new Carrera DIGITAL 124 track.

Safety instructions

• **WARNING!** Not suitable for children under 36 months. Danger of suffocation due to small parts which may be swallowed. Caution: risk of pinching caused by function.

• **WARNING!** This toy contains magnets or magnetic components. Magnets attracting each other or a metallic object inside the human body may cause serious or fatal injuries. Seek medical attention immediately if magnets are swallowed or inhaled.

• **WARNING!** Only allow children at least 8 years old to use the battery charger. Sufficient instruction must be given to enable the child to use the battery charger in a safe way and explain that it is not a toy and must not be played with.

• The transformer is not a toy! Do not short-circuit the transformer's connections! Note to parents: Regularly inspect the transformer for damage to the cable, plug or housing! Only operate the toy with recommended transformers! The transformer may no longer be used if it is damaged! Only operate the racetrack with a transformer! If play is interrupted for longer periods, it is recommended to separate the transformer from the power supply. Do not open transformer or speed controller housings!

Important note to parents: Transformers and power supply units are not suitable to be used as toys. The use of such products needs to be constantly supervised by the parents.

• Regularly check the track, cars and charger for damage to cables, plugs and housings! Replace defective parts.

• The car racetrack is not suitable for outdoor operation or operation in wet locations! Keep away from liquids.

• Do not place any metal parts onto the track to avoid short-circuits. Do not place the track in the immediate vicinity of delicate objects, as these could be damaged by cars hurled from the track.

• Disconnect the plug before cleaning or servicing the racetrack! Only use a damp cloth for cleaning, no solvents or chemicals. When it is not in use, store the track in a dry and dust-protected location, preferably in the original cardboard box.

• Do not operate race track at face- or eye-level – risk of injury due to cars being catapulted off the track.

• Misuse of transformer can cause electrical shock.

• The toy is only to be connected to Class II equipment bearing the following symbol.



• The toy and the charger must only be used with a transformer designed for toys.
• Not to be used with controllable transformers.
• If the supply cord is damaged, it must be replaced by the manufacturer, its service agent or similarly qualified persons in order to avoid danger.

Note:
The vehicle may only be operated again in a completely assembled condition. Assembly may only be carried out by an adult.

This appliance is not intended for use by persons (including children) with reduced physical, sensory or mental capabilities, or lack of experience and knowledge, unless they have been given supervision or instruction concerning use of the appliance by a person responsible for their safety. Children should be supervised to ensure that they do not play with the appliance. Instruct the child not to try and recharge non-rechargeable batteries because of the danger of explosion.

Declaration of Conformity

The company Stadlbauer Marketing + Vertrieb GmbH, hereby confirms that the product „2.4 GHz WIRELESS+“ complies with the fundamental requirements of Guideline 2014/53/EU (RED). The Declaration of Conformity can be called up from the following address: carrera-toys.com

Contents of package

- 1 Audi R8 LMS "Yaco Racing, No.16"
- 1 Mercedes-Benz SLS AMG GT3 "Martini No.33", Hankook 12h Zandvoort
- 11 Standard straights
- 1 Control Unit
- 1 Carrera DIGITAL 124 double lane change section (2 track parts)
- 1 Carrera DIGITAL 124 lane change section, right (2 track parts)
- 8 Curves 1/60°
- 2 WIRELESS+ Speed controllers
- 1 WIRELESS+ Receiver
- 1 WIRELESS+ Twin charging station
- 2 LiPo rechargeable battery for speed controller
- 1 Transformer
- Outside shoulders for curves
- Inside shoulders for curves
- Shoulder end sections
- Supports
- Guard rails
- Track section bolts
- Replacement contacts
- Accessories

InstructionsTrack length: 26.25 ft/ 8,0 m
Dimensions when assembled: 11.75 x 6.20 f ft./ 358 x 189 cm

Technical advice for assembly

- 1 Connecting track + Control Unit
- 2 WIRELESS+ Receiver
- 3 WIRELESS+ Twin charging station
- 4 Lane change section right input
- 5 Lane change section right output
- 6 Double lane change section input
- 7 Double lane change section output
- 8 Infrared sensor:

The infrared sensor MUST be located on the switch that functions as the entry rail (dark diode).

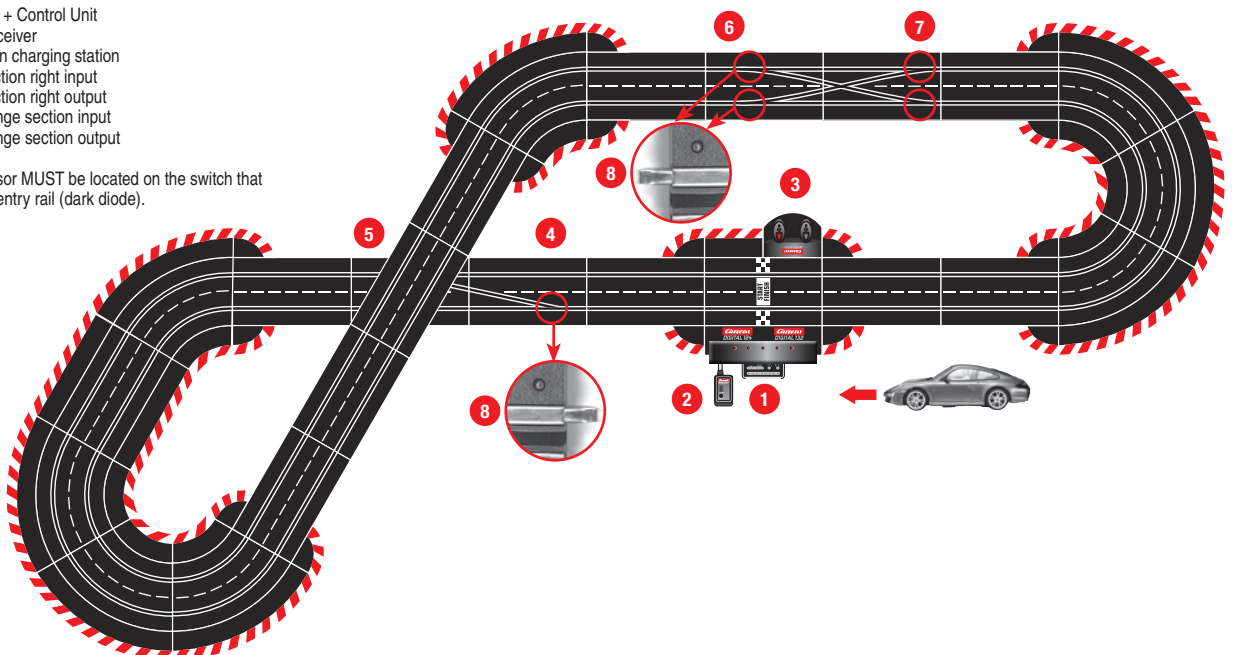

Important Information

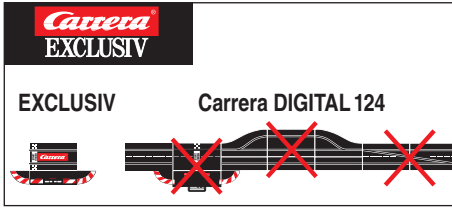

Please note that Exklusiv (analog system) and Carrera DIGITAL 124/132 (digital system) involve two separate and completely independent systems. We hereby expressly indicate that both systems must be kept separate when setting up the track, i.e. no connecting rail from Exklusiv may be used together with the connecting rail and Control Unit of the Carrera DIGITAL 124/132, even if only one of the two connecting rails (Exklusiv connecting rail or Carrera DIGITAL 124/132 connecting rail and Control Unit) is attached to the current supply. Furthermore, no other Carrera DIGITAL 124/132 components (switches, electronic lap counter, pit stop) may be built into an Exklusiv course, i.e. via analog operation.

Non-compliance with the above information may result in damage or destruction of the respective Carrera DIGITAL 124/132 components. In this case no warranty may be claimed.

Description

WIRELESS+ is the latest new cordless racetrack delight for Carrera DIGITAL124 and Carrera DIGITAL 132. The 2.4 GHz radio technology with frequency-hopping is free of interference and offers a range of up to 15 metres. Thanks to powerful lithium polymer rechargeable battery, continuous play for up to eight hours is possible and stand-by operation for over 80 days. WIRELESS+ in conjunction with DIGITAL 124 offers wireless freedom for up to four drivers on the racetrack.

Before first use

Before first using the speed controller, the rechargeable battery supplied (2) must be inserted in the controller. Unscrew the battery compartment (1) on the underside of the speed controller.

Connect the battery plug into the socket in the speed controller and put the battery in place in the compartment. Finally screw down the cover of the battery compartment again. The battery is part-loaded at the factory, but it should be charged completely before being used for the first time.

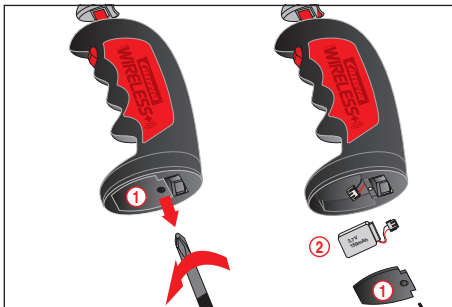

Care of the battery

To make sure the battery performs well for as long as possible, the following points should be observed regarding its care and storage.

- Before first using them, new batteries should always be charged fully.
- With a fully-charged battery, continuous play is possible for up to eight hours. When the battery power is falling off, range of the speed controller will diminish. As soon as you notice this, the battery should be fully recharged.
- If it is not to be used for an extended period, remove the battery and store the controller at room temperature (16-18 °C) in a dry place. To prevent a deep discharge of the battery, the stored battery should be charged every 2 to 3 months.

Assembly instructions

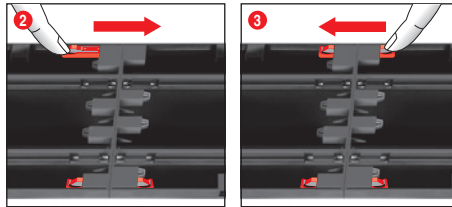
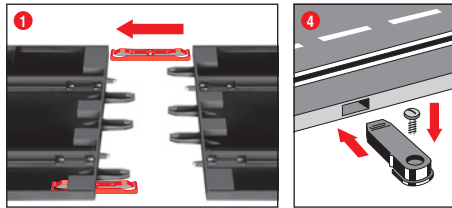

1 + 2 + 3 Before assembling please insert the connecting clips in the track as shown in figure 1. Stick tracks together on a flat base. Move the connecting clips according to figure 2 in direction of the arrow until they audibly snap in. The connecting clip may also be inserted later. The connecting clips can be removed into both directions by simply pressing down the clamped nose (see fig. 3).

4 Fastening: To fasten the track sections on a board, it is necessary to use the track section fasteners (Item no. 20085209, not contained in the package).

Note:

Carpeting is not a suitable foundation on which to build the track because of static charging, formation of fluff and ready inflammability.

The Position Tower (PT) is suitably connected to the shoulder connecting section (F) or to the Adapter Unit (AU); the latter can be positioned at any place within the racetrack.

Guard Rails and Supports

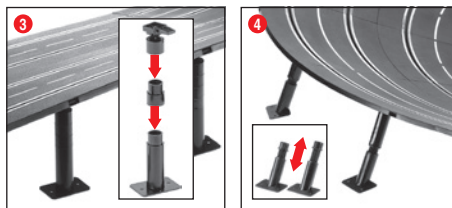
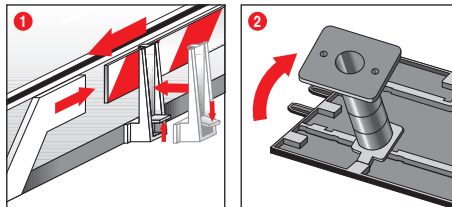

1 Guard rails: Guard rail mounts are fitted by tilting them upwards onto the verge of the track.

2 + 3 Supporting raised sections: The shank of the ball pivot is to be inserted into the square slots provided on the underside of the track. The supports can be made higher by using the extensions. The pedestal of the supports can be screwed to a base if required (screws not included).

4 Supporting steep curves:

Slanting supports of the right height are provided to support steep curves. Fix the nonadjustable supports at the beginning and end of the curves. Insert the heads of the supports in the round slots of the underside of the track.

Electrical connection

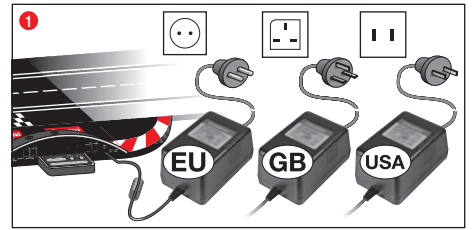

1 Connect the transformer plug with the Control Unit.

Note: To avoid short-circuits and electrocution, the toy may not be connected using foreign devices, plugs, cables or other objects foreign to this toy. The Carrera DIGITAL 124 car racetrack only works properly with an original Carrera DIGITAL 124 transformer.

The PC interface (PC Unit) may only be operated together with the original Carrera PC Unit.

Car components

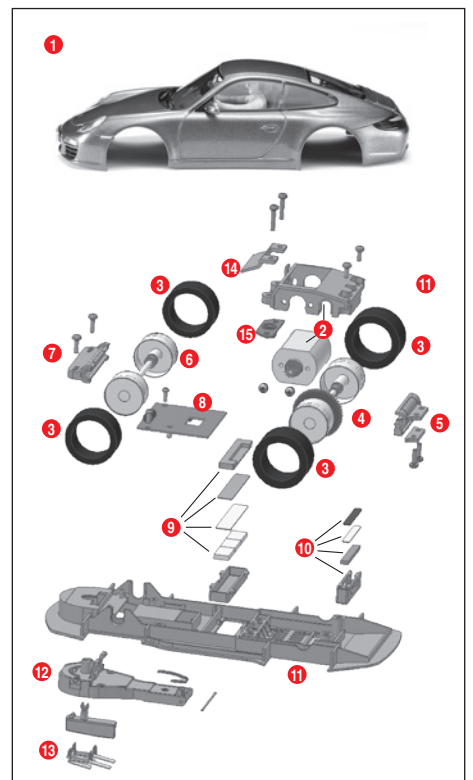

- 1 Body
- 2 Engine block
- 3 Tyres
- 4 Rear axle
- 5 Rear axle receptacle including spacer plate
- 6 Front axle
- 7 Front axle mounting
- 8 Board
- 9 Central magnet
- 10 Rear magnet
- 11 Chassis
- 12 Rocker arm including spring
- 13 Guide keel with double sliding contact
- 14 Center magnet retainer
- 15 Fastening plate

Note: vehicle construction depends on the model.

The designation of the individual parts may not be used as order numbers.

Connections Control Unit

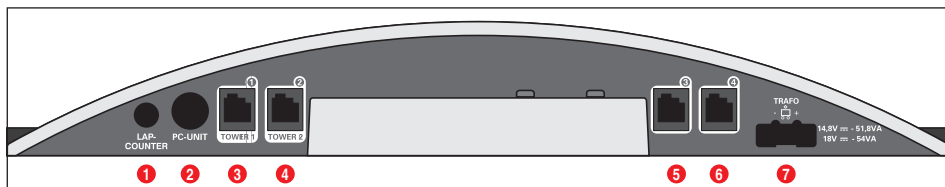

Connections (from left to right):

- 1 Connection for Lap Counter 20030342
- 2 Connection for Carrera AppConnect 20030369, PC-Unit or Lap Counter 20030355
- 3 Connector 1 for speed controller, speed controller extension set or WIRELESS+ receiver
- 4 Connector 2 for WIRELESS Tower 20010108
- 5 Connector 3 for speed controller
- 6 Connector 4 for speed controller
- 7 Connection for DIGITAL 124 / DIGITAL 132 power supply

General information on connectors 1-4:

When a WIRELESS+ receiver is used, it must be plugged into connector 1. Optionally a WIRELESS Tower 20010108 can be plugged into connector 2. When only the WIRELESS+ receiver is used, connector 2 is to be left empty.

Additional wired speed controllers may be plugged into connectors 3 and 4. Please note that these will use address 5 and 6 then.

Using the speed controller extension set 20030348 it has to be plugged into connector 1. The cars' addresses will be allocated as follows:

- Speed controller extension set = address 1, 3 and 4
- connector 2 = address 2
- connector 3 = address 5
- connector 4 = address 6

Note:

a combination of WIRELESS and speed controller extension set is not possible!

Please note that in DIGITAL 124 the number of cars is restricted to four.

3

To bind the second speed controller, follow the same procedure. Press the "SET" button (2) on the receiver twice, until the figure 2 appears (1). Then press the binding button (3) on the second speed controller.

4

To display the address set for the speed controller, press once on the binding button (2) on the top of the speed controller. The LED (1) will then flash, according to the address set.

If the speed controller is not actuated, it switches automatically after about 20 seconds into energy-saving mode. The speed controller can be reactivated by pressing the tappet or the lane-change button.

Control elements Control Unit

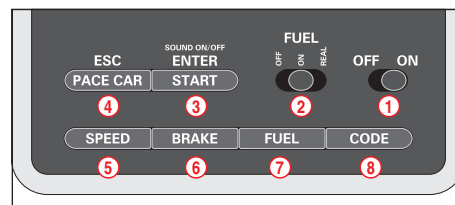

- 1 On/off switch
- 2 Switch for fuelling function
- 3 Button to start the race / acknowledge programming
- 4 Button for Pace Car / termination of programming
- 5 Button for setting basic speed
- 6 Button for setting braking performance
- 7 Button for setting fuel tank capacity
- 8 Programming button for cars

General operating information

Some buttons are assigned with different tasks. In order to set a function you need to use key combinations. Any programming steps can be cancelled with button (4) "ESC/PACE CAR". You will find further details in the course of this manual.

Connecting the receiver

Connect the receiver according to the symbol to either of the two sockets on the control unit which are marked Tower 1 and Tower 2. For operating four WIRELESS+ speed controllers only one 2.4 GHz receiver is required.

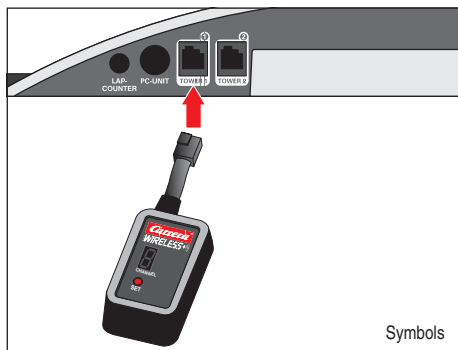

Symbols

Charging the speed controllers

Before first being used, the WIRELESS+ speed controllers should be fully charged. Place the speed controllers in the charging station and switch on the control unit. While the unit is charging, the LEDs (1) on the speed controllers will flash. When charging is completed, the LEDs (1) will light up continuously.

When using a lithium polymer rechargeable battery, it is possible to top up the speed controller at any time.



Binding process

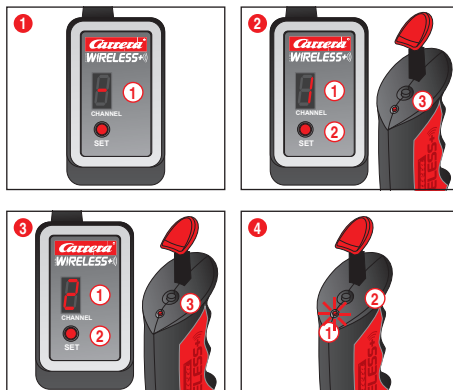

Before the speed controller can be used to control the cars, it must be "bound" to the receiver. To do this, switch on the control unit.

1 The receiver indicates it is ready for operation by a revolving light signal in the segment display (1).

2 Push the "SET" button (2) once until the figure 1 appears in the segment display (1). The number shown is then the address of the car. Switch to the next address by further pressing the button.

Now press the binding button (3) on the top of the speed controller. The speed controller signals a successful binding process with flashing of the LED, while the receiver indicates it by revolving lights in the segments. The binding process is now complete and the speed controller is ready for use.

Encoding/programming of cars to the according speed controllers



To encode a car place it on the track and switch on the Control Unit. Press "Code" button once (8), fig. 1; the first LED starts to light, fig. 2. Then push lane-change-button once on the relevant speed controller, fig. 3. In case the car is equipped with lights they will start to flash and the Control Unit's LEDs 2-4 will light successively. Once encoding has been carried out the middle LED lights permanently (fig. 4) and the car is allocated to the speed controller.

Note: This kind of encoding requires to only have the car on the racetrack which shall be encoded.

Connecting the charging unit

The charging unit is connected at the rear of the control unit. To site the charging unit at any other place on the track, an adapter unit 20030360 will be needed.

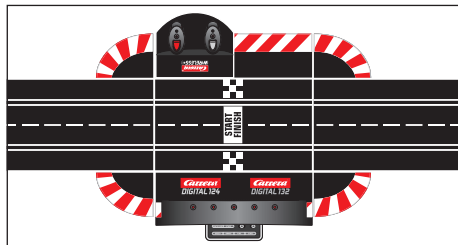

Rear view of the control unit

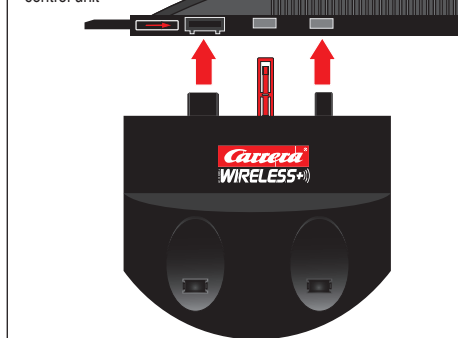

Preparation of start

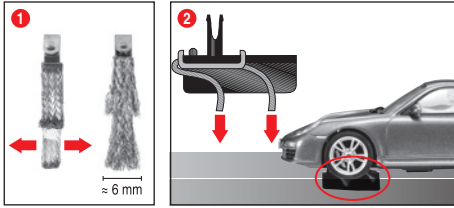

This Carrera DIGITAL 124 vehicle ideally matches the Carrera track system scale 1:24.

1 + 2 Optimally setting up the grinders:

To ensure proper and continuous driving, slightly fan out the ends of the contact brushes 1 and bend them towards the track as per fig. 2. Only the end of the contact brush should have contact to the track and may be cut off slightly in case of wear. Dust and abrasion should be removed from track material and sliding contacts from time to time.

During operation small car parts as spoilers or mirrors may get off or brake due to being original detailed parts of the car model. To avoid this it is possible to remove them before operation.

Points function

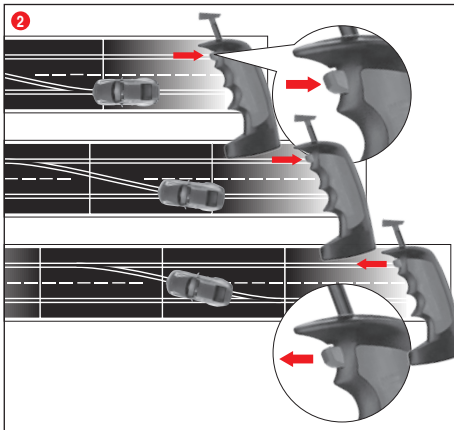

1 Make sure that the car's guide keel is located inside the track slot and that the double sliding contact is in contact with the current carrying track. Place the cars onto the connecting track.

2 When changing lanes, you must keep the button on the speed controller depressed until the car has passed the point.

Light function on/off

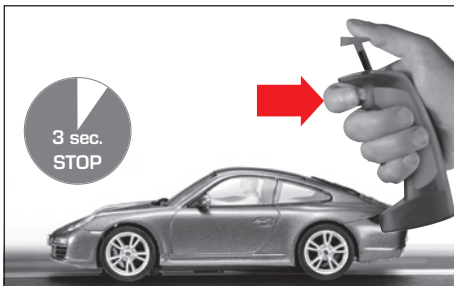

The car programmed to the speed controller will have to come to a stop for at least 3 seconds before the light can be switched on or off by the push of the lane-change-button.

Note:
applies only to models fitted with lighting

Encoding/programming of Autonomous Car

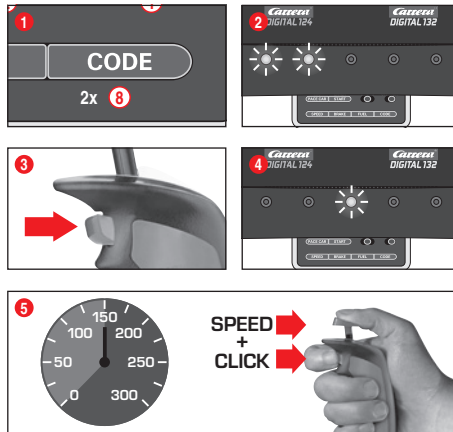

Switch on the Control Unit, place the car to be encoded on the track and press „Code“ 8 twice, fig. 1. The first two LEDs at the Control Unit start to light, fig. 2. Now push the lane-change button at the speed controller, fig. 3; LEDs 3-5 will light successively. Wait until the middle LED lights again, fig. 4. Activate the speed controller's tappet until the car has reached the desired speed. Now push lane-change button again, fig. 5. Autonomous Car's encoding is completed now.

Note: This kind of encoding requires having **only the car** on the track **which is to be encoded**. The programming of the Autonomous Car will be maintained unless the car is not being recorded. The Autonomous Car is always displayed with address 7 in combination with the Position Tower.

Encoding/programming Pace Car

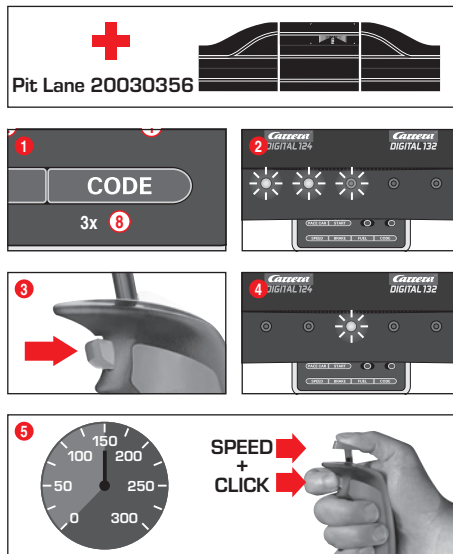

(only in combination with Pit Stop Lane #20030356)
Switch on the Control Unit, place the car to be encoded on the track and press „Code“ 8 three times, fig. 1. The first three LEDs at the Control Unit start to light, fig. 2. Now push the lane-change button at the speed controller, fig. 3; LEDs 2-5 will light successively. Wait until the middle LED lights again, fig. 4. Activate the speed controller's tappet until the car has reached the desired speed. Now push lane-change button again, fig. 5. The Pace Car's encoding is completed now and the car enters the Pit Stop Lane.

Note: This kind of encoding requires having **only the car** on the track **which is to be encoded**. The programming of the Pace Car will be maintained unless the car is not being recorded. The Pace Car is always displayed with address 8 in combination with the Position Tower.

Extended Pace Car function

After the Pace Car's encoding has been completed it will automatically enter the Pit Lane during the first laps. In order to start the Pace Car please push the button „Pace Car“ 4 once. The LEDs 2 and 3 at the Control Unit will light and the Pace Car will leave the Pit Lane. The Pace Car will now drive as long as the button „Pace Car“ is pushed again. LED 2 stops lighting and the car automatically enters the Pit Lane within the current lap.

Display of position Autonomous and Pace Car

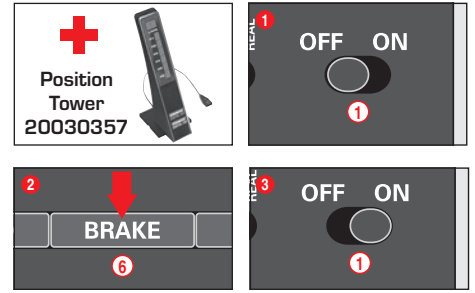

(only in combination with Position Tower #20030357)
The position of the Autonomous Car (address 7) and of the Pace Car (address 8) can be displayed at the Position Tower. This function can be activated at the Control Unit. Therefore switch off the Control Unit and keep the „BRAKE“ button 6 pushed, fig. 2, switch on the racetrack and release the „BRAKE“ button again. By pushing the button again the function may be changed:

- 1 LED lights = no display
- 2 LEDs light = display at the Position Tower

Set the function requested and confirm your choice via „START/ENTER“.

Setting of the cars' basic speed

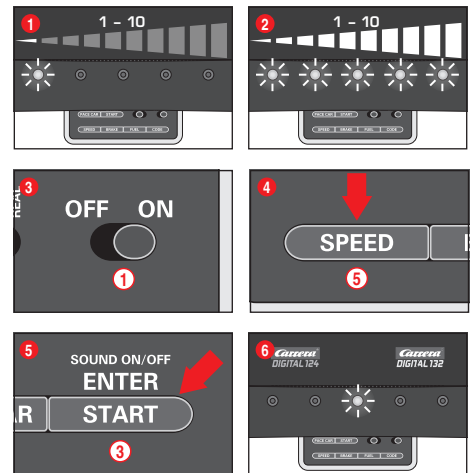

The setting of the basic speed can be effected individually for one and/or several cars. The cars which are to be adjusted have to be positioned on the track. The setting can be carried out on 10 levels with the 5 LEDs indicating the different levels by flashing or permanent lighting.

- 1 1 LED lights = low speed
- 2 5 LEDs light = high speed

Switch on the Control Unit, place the cars to be adjusted on the track and press „SPEED“ 5 once. A certain number of LEDs will now light, showing the speed level last used. Push the „SPEED“ button 5 as many times until you have reached the speed desired. Confirm by pressing „ENTER/START“ 3. A short running light and the lighting of the middle LED confirms completion of the setting, fig. 6.

Setting of cars' braking performance

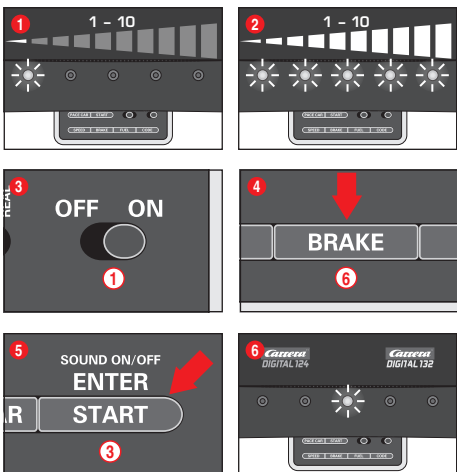

(only for cars operated with speed controllers)

The setting of the braking performance can be effected individually for one and/or several cars. The cars which are to be adjusted have to be positioned on the track. The setting can be carried out on 10 levels with the 5 LEDs indicating the different levels by flashing or permanent lighting.

- 1 1 LED lights = low braking effect
- 2 5 LEDs light = high braking effect

Switch on the Control Unit, place the cars to be adjusted on the track and press "BRAKE" (6) once. A certain number of LEDs will now light, showing the brake step last used. Push the "BRAKE" button (6) as many times until you have reached the braking performance desired. Confirm by pressing "ENTER/START" (3). A short running light and the lighting of the middle LED confirms completion of the setting, fig. 6.

Setting fuel tank capacity

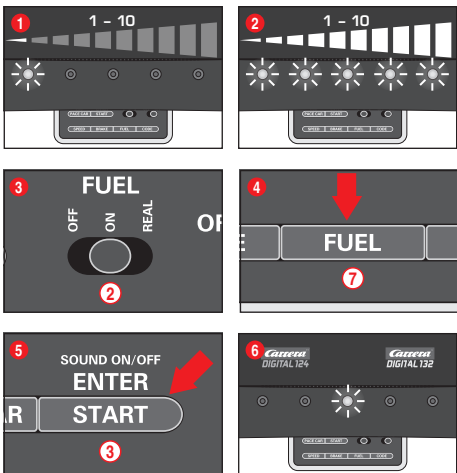

(only for cars operated with speed controllers)

The setting of the fuel tank capacity in combination with the Pit Lane (20030356) is effected for all cars simultaneously. The setting can be carried out on 10 levels with the 5 LEDs indicating the different levels by flashing or permanent lighting.

- 1 1 LED lights = low fuel capacity
- 2 5 LEDs light = full tank

Switch on the Control Unit, place the cars to be adjusted on the track and activate the fuelling function by means of the slide switch (2), fig. 3. Press the "FUEL" button (7) once. A certain number of LEDs will now light, showing the fuel capacity last used. Push the "FUEL" button (7) as many times until you have reached the fuel capacity desired. Confirm by pressing "ENTER/START" (3). A short running light and the lighting of the middle LED confirms completion of the setting, fig. 6.

Extended fuelling function

You can choose between 3 modes via the sliding switch (2), fig. 3:

- OFF = cars don't consume any "petrol"
 - ON = cars consume "petrol"
 - REAL = maximum speed depending on fuel tank capacity / cars consume "petrol" (only in combination with Pit Lane 20030356 or Pit Stop Lane 20030346 and Pit Stop Adapter Unit 20030361)
- When driving in "REAL-mode" the car with a full tank is "heavier",

drives slower and shows a lower braking effect; a car with an empty tank is "lighter", drives faster and shows a higher braking effect. The current fuel tank capacity and the "fuel consumption" can only be displayed in combination with the Driver Display 20030353 and Pit Stop 20030356.

Refuelling of cars with Pit Lane 20030356 and Driver Display 20030353

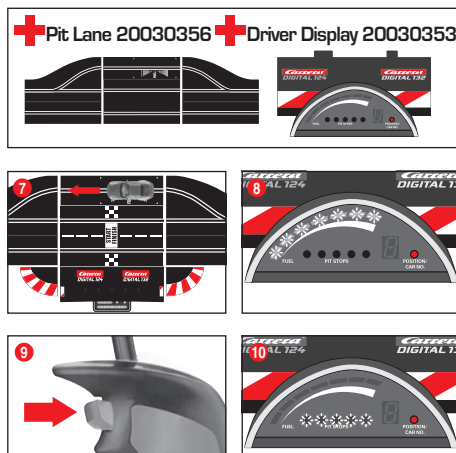

The car's present tank capacity can be read via the bar display with 5 green and 2 red LEDs at the Driver Display. For refuelling drive your car into the Pit Lane across the refuelling sensor fig. 7. The bar display now starts to flash, fig. 8, and the car can be refuelled by keeping the lane-change button pushed, fig. 9. The number of refuellings are indicated by flashing or lighting of the yellow LEDs, fig. 10 (also see Driver Display).

Note: cars with an empty tank are disregarded for lap-counting in combination with Position Tower 20030357.

Setting of tank capacity at the start of the race

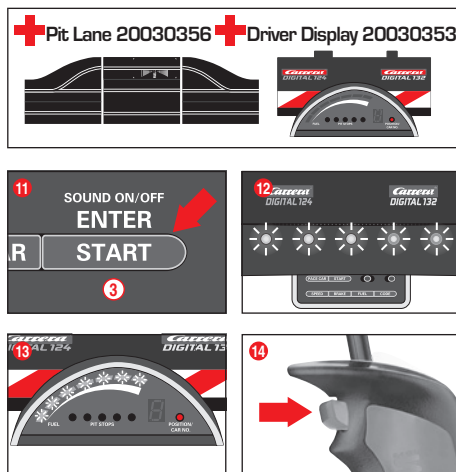

(only in combination with Pit Lane 20030356 and Driver Display 20030353)

Irrespective of the basic setting of the tank capacity it is possible to individually set the tank capacity for one or several cars at the race's start for the number of laps till the first pit stop. Push "START/ENTER" once (3); the 5 LEDs at the Control Unit will light permanently, fig. 12, and the Driver Display's bar display will flash, fig. 13. Clicking the lane-change button at the corresponding speed controller enables you to change the fill level, fig. 14.

Deactivating Settings Keys

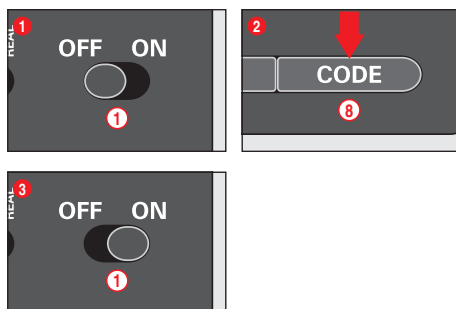

To deactivate the keys for setting Speed, Brake and Fuel, proceed as follows: Hold down the Code Key (8). While holding down the Code Key (8), turn on the Control Unit and then release the Code Key. To reactivate the above keys, repeat the procedure just described.

Extended Pit Lane function

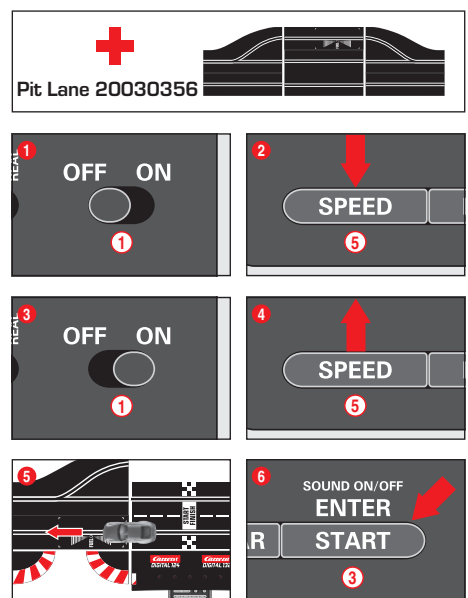

(only in combination with Pit Lane 20030356)

It is possible to activate/deactivate the lap counting function in the Pit Lane 20030356 or Pit Stop Lane 20030346 with the Pit Stop Adapter Unit 20030361. Switch off the Control Unit, keep "SPEED" button (5) pushed, switch on Control Unit and release "SPEED" button (5). By pushing the button again, 1 or 2 LEDs will light depending on the setting.

- LED 1 = lap counting function deactivated
- LED 1 + 2 = lap counting function activated

Select the desired setting and push or drive a car across the Pit Lane Sensor, fig. 5. The settings will now be adopted. Push "START/ENTER" (3) for leaving the settings again.

Sound ON/OFF

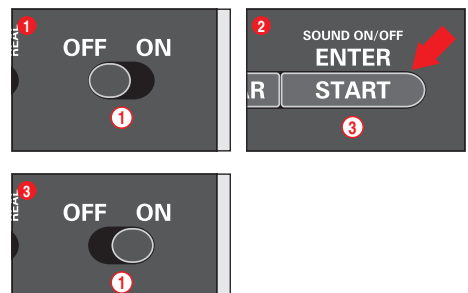

The confirmation sound when crossing the sensors and the key sound can be switched off. Switch off the Control Unit and keep the "START/ENTER" button (3) pushed, switch on the racetrack and release "START/ENTER" (3) again. The acknowledgement sound for switching on the Control Unit cannot be switched off however.

Reset function

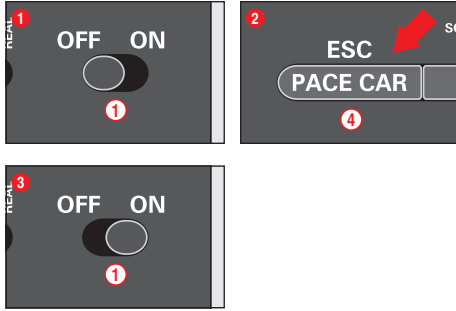

To restore the Control Unit to factory settings the Control Unit offers a reset function.

Switch off the Control Unit and keep the "ESC/PACE CAR" button pushed; switch on the racetrack and release the button again. All previous settings for speed, braking performance, tank fuel capacity, sound and lap counting will be restored to factory settings. The cars' settings will remain unaffected by this measure unless they are placed on the racetrack.

Factory settings:

- speed = 10
- braking performance = 10
- tank capacity = 7
- sound = ON
- display of position for Autonomous and Pace Car = OFF

Energy-saving mode

After 20 minutes of non-usage the Control Unit switches to energy-saving mode and all displays such as Position Tower, Driver Displays and Startlight are turned off. To reactivate the controller, switch it off for 2 or 3 seconds, then switch it on again. All settings will be kept.

Replacement of double contact brushes and guide keel

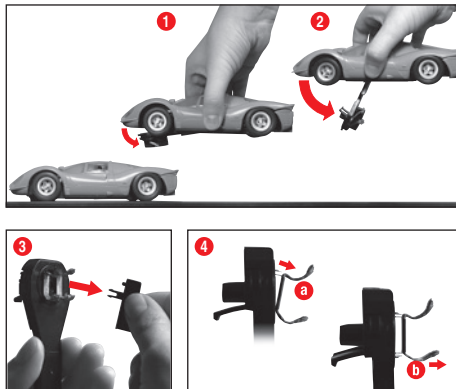

In case the car is lifted, the rocker bar folds up slightly (fig. 1).

For changing the guide keel or the double contact brushes the rocker bar can be folded up widely according to fig. 2.

3 For changing the guide keel and the double contact brushes the guide keel should be removed first.

4 Afterwards both double contact brushes can be removed and changed. Please take care that in stage one the upper contact brush 4 a is only pulled out partly and in stage two the double contact brush is pulled out completely with the contact brush 4 b. For inserting please proceed the same way.

Height adjustment car chassis

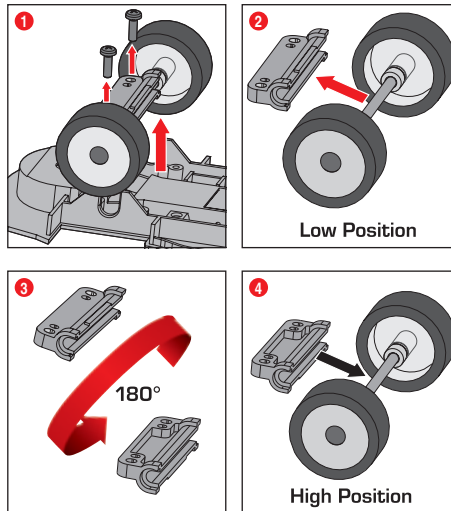

Before you can begin adjusting the chassis and the magnets it is necessary to detach the car body from the vehicle. Remove the mounting screws on the underside of the car and lift off the car body.

Adjusting the height of the front axle

1 Remove the two screws from the front axle mounting and detach the entire front axle including the mounting from the chassis. 2 Detach the mounting from the axle, turn it through 180 degrees 3 and insert the axle back into the mounting 4. Now you can return the front axle and mounting unit to the chassis.

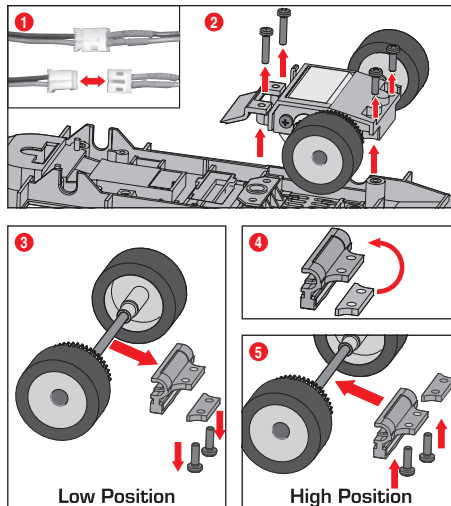

Adjusting the height of the rear axle

To simplify the procedure, carefully detach the plug connection between the motor and the circuit board 1. Remove the two screws from the motor block unit and detach the magnet retainer from the chassis. Now remove the two rear screws and detach the entire motor block 2.

Turn the motor block around and remove the two screws from the rear axle mounting. Remove the spacer plates and the rear axle unit including the mounting 3. To adjust the height, place the spacer plate in the motor block 4 and tighten the screws of the rear axle unit. 5

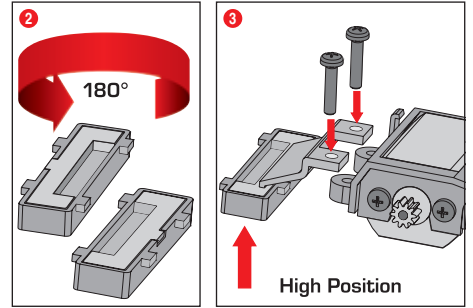
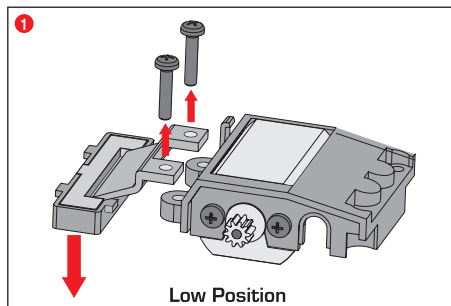

Adjusting the central magnet

If required, the central magnet can also be adjusted. Remove the magnet unit from the chassis in its entirety 1, turn it horizontally by 180 degrees 2 and return it to the chassis. Then mount the magnet retainer 3 and restore all plug connections.

Changing the light board

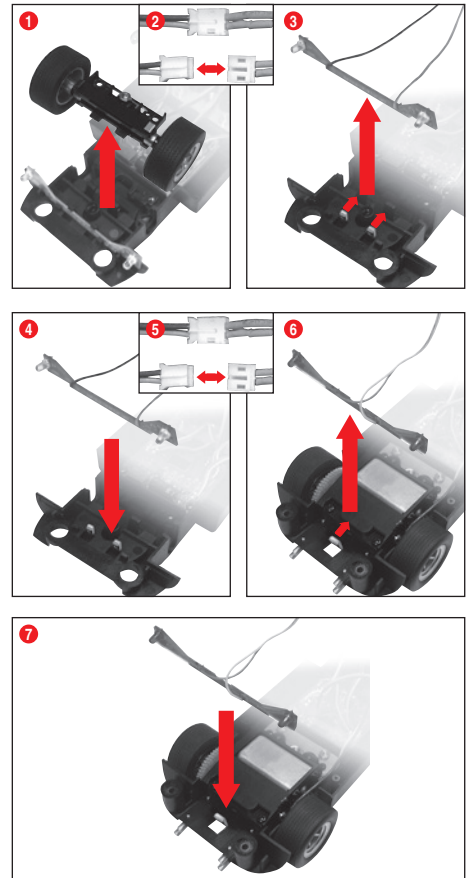

ATTENTION! Depending on the model, the light boards might be screwed tight.

Front light: To change the light boards unscrew the car's upper part from the chassis. Unscrew the front axle according to fig. 1 and remove the cables between the front light and the car board (fig. 2). Slightly bend down the catch hook (fig. 3) and pull up the light board. Insert the light board (fig. 4), until the catch hook latches in. Screw in the front axle and fit the cables together according to their colours.

Rear light: Remove the cables between the rear light and the car board according to fig. 5. Slightly bend down the catch hook (fig. 6) and pull up the light board. Insert the light board until the catch hook latches in (fig. 7) and fit the cables together according to their colours.

Maintenance and care

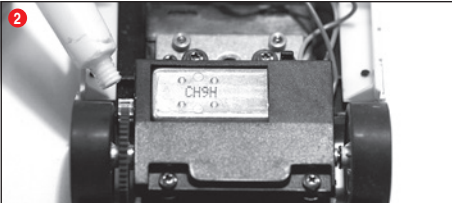
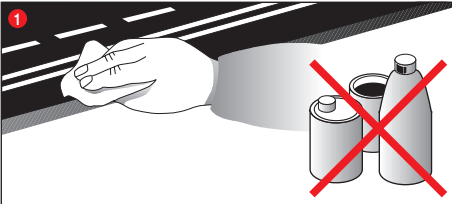

To ensure a proper operation of the motor-racing circuit, all race-track components should be regularly cleaned. Pull the plug prior to cleaning.

- 1 Racetrack:** Keep the track surface and track slots clean with a dry cloth. Do not use any solvents or chemicals for cleaning. When it is not in use, store the racetrack in a clean and dust-protected location, preferably in the original cardboard box.
- 2 Car check:** Clean axle and wheel bearings, pinion gears, gear-wheels and bearings and lubricate using a resin- and acid-free grease. You can use a toothpick or similar as aid. Regularly check the condition of sliding contacts and tyres..

Troubleshooting Driving tips

- Troubleshooting:**
In case of any malfunctions, please check the following:
- Has the connection to the power supply been established correctly?
 - Have transformer and speed controllers been connected correctly?
 - Are the track connections faultless?
 - Are the racetrack and track slots clean and free of any foreign objects?
 - Are the sliding contacts in order and do they make contact with the track slot?
 - Are the cars correctly coded to the according speed controller?
 - The track's current feed will be switched off automatically for 5 seconds, if there is an electrical short circuit: this will be notified by audible and visual signals.
 - Are the cars placed on the track in running direction? In case of non-functioning push the running direction switch which is on the car's bottom.
 - Is the adapter unit correctly installed facing the direction of travel?
 - Is the speed controller battery properly connected?
 - Is the battery fully charged?
 - Does the LED on the controller flash while charging?
 - Is the speed controller bound to the receiver?
 - Has the speed controller got a duplicate address assignment?

Note:
During operation small car parts as spoilers or mirrors may get off or brake due to being original detailed parts of the car model. To avoid this it is possible to remove them before operation.

- Driving technique:**
- You can drive fast along the straight track but you should brake before the curve and then accelerate again when coming out of the curve.
 - Do not fasten or block the vehicles when the motor is running: overheating or damage to the motor could result otherwise.

Note: When using track systems which are not manufactured by Carrera the existing guide keel has to be replaced by the special guide keel (#20085309). While using the Carrera crossing (#20020587) or high banked curve 1/30° (#20020574) slight driving noise might occur which is due to the full-scale genuineness and does not affect flawless operation.

Technical specifications

GB
Output voltage: Toy transformer
18 V --- 54 VA
Lithium polymer rechargeable battery:
3,7 V --- 150mAh · 0,55 Wh

- Electricity modes:**
- 1.) Operating mode = cars are operated via speed controllers
 - 2.) Idle mode = speed controllers not activated, no game
 - 3.) Stand-by mode = after approx. 20 minutes idle mode the connecting section switches to stand-by mode. LED flashes at long intervals. **CURRENT CONSUMPTION < 0,5 watt / 0,5w**
To reactivate the controller, switch it off for 2 or 3 seconds, then switch it on again. The racetrack is then once again in standby mode.
 - 4.) Off-state = power supply unit disconnected from mains supply



This device is marked by "selective sort through" symbol related to sort through domestic, electric and electronic, waste. This means the product must be treated by a specialized "sorting/collecting" system in accordance with European directive 2012/19/EU, to reduce the impact upon environment. For more precise information, please contact your local administration. Electronical product which are not going through special collecting, are potentially dangerous for environment and human health, because of dangerous substance.

USA
Output voltage: Toy transformer
18 V --- 54 VA (18 V --- 3,0 A)
Lithium polymer rechargeable battery:
3,7 V --- 150mAh · 0,55 Wh

- Electricity modes:**
- 1.) Operating mode = cars are operated via speed controllers
 - 2.) Idle mode = speed controllers not activated, no game
 - 3.) Stand-by mode = after approx. 20 minutes idle mode the connecting section switches to stand-by mode. LED flashes at long intervals. **CURRENT CONSUMPTION < 0,5 watt / 0,5 w**
To reactivate the controller, switch it off for 2 or 3 seconds, then switch it on again. The racetrack is then once again in standby mode.
 - 4.) Off-state = power supply unit disconnected from mains supply

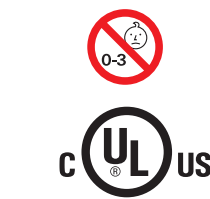

Conforms to the safety requirements of ASTM F963.



Requirement for FCC Part 15

Warning: Changes or modifications not expressly approved by the party responsible for compliance could void the user's authority to operate the equipment.

Note: This equipment has been tested and found to comply with the limits for a Class B digital device, pursuant to Part 15 of the FCC Rules. These limits are designed to provide reasonable protection against harmful interference in a residential installation. This equipment generates, uses and can radiate radio frequency energy and, if not installed and used in accordance with the instructions, may cause harmful interference to radio communications. However, there is no guarantee that interference will not occur in a particular installation. If this equipment does cause harmful interference to radio or television reception, which can be determined by turning the equipment off and on, the user is encouraged to try to correct the interference by one or more of the following measures:

- Reorient or relocate the receiving antenna.
- Increase the separation between the equipment and receiver,
- Connect the equipment into an outlet on a circuit different from that to which the receiver is connected.
- Consult the dealer or an experienced radio/TV technician for help.

Warnings

Guidelines and warnings about using the LiPo battery/ batteries:
LiPo rechargeable batteries are much more sensitive than the traditional alkaline or NiMH rechargeables. For this reason all instructions and warnings must be scrupulously observed. Incorrect treatment of LiPo rechargeable batteries may cause a fire. In handling, charging and using the LiPo battery/batteries supplied, you take over all responsibility for the risks attached to lithium batteries.

- Non-rechargeable batteries must not be recharged!
For recharging batteries, only the charging cradle supplied may be used. If this instruction is disregarded, there is a risk of fire which may endanger your health and/or cause damage to property. NEVER use any other charging unit!
- Rechargeable batteries may only be recharged under adult supervision. When charging, never leave the battery unattended. When you recharge the battery, you should always be in the vicinity to keep watch on the process so that you can react to any possible problem.
- If the battery swells or deforms during either discharge or charging process, stop the process immediately. Remove the battery as fast and as carefully as possible and place it on a safe and open area away from any flammable materials, and keep it under observation for at least 15 minutes. If you continue to charge or discharge a battery which has already started to swell or deform, there is danger of fire! Even at the slightest sign of swelling or deforming, the battery must be taken out of service.
- The battery supplied must be charged in a safe place away from flammable materials.
- Store the battery at room temperature (16 - 18 °C) in a dry place. Do not expose the battery to direct sunlight or any other sources of heat. Temperatures over 50 °C are generally to be avoided.
- Always recharge the battery after use to avoid the possibility of its becoming deep discharged. When it is not in use, recharge the battery from time to time, say every 2-3 months. Failure to observe the methods of handling described above may lead to defects.
- When changing batteries do not use any sharp or pointed objects or tools. Avoid damaging the protective foil around the battery at all costs.
- When replacing defective batteries, only the recommended battery types may be used. Damaged or unusable batteries are hazardous waste, and must be disposed of accordingly.
- Never throw batteries, rechargeable or otherwise, on the fire or expose them to high temperatures. This may cause a fire or an explosion.
- The electrolyte and electrolyte vapour in the LiPo batteries are hazardous to health. Always avoid direct contact with electrolyte. If electrolyte makes contact with skin, eyes or other parts of the body, it must immediately be washed out or off with plenty of fresh water and a doctor must be consulted.
- Rechargeable batteries are not toys and must not fall into the hands of children. Keep batteries inaccessible to children.
- The connector clips / battery connections must never be short-circuited!
- The toy is only to be operated with a transformer or power pack designed for use with toys!
- The transformer / the power pack is not a toy!



Stadlbauer Marketing + Vertrieb GmbH · Rennbahn Allee 1 · 5412 Puch / Salzburg · Austria

carrera-toys.com